

Dominik Witt

dominik.witt@phaina.com



Digitaler B2B Vertrieb

PHAINA

01 Problem – Technische Sprachbarriere



01 Problem – Technische Sprachbarriere

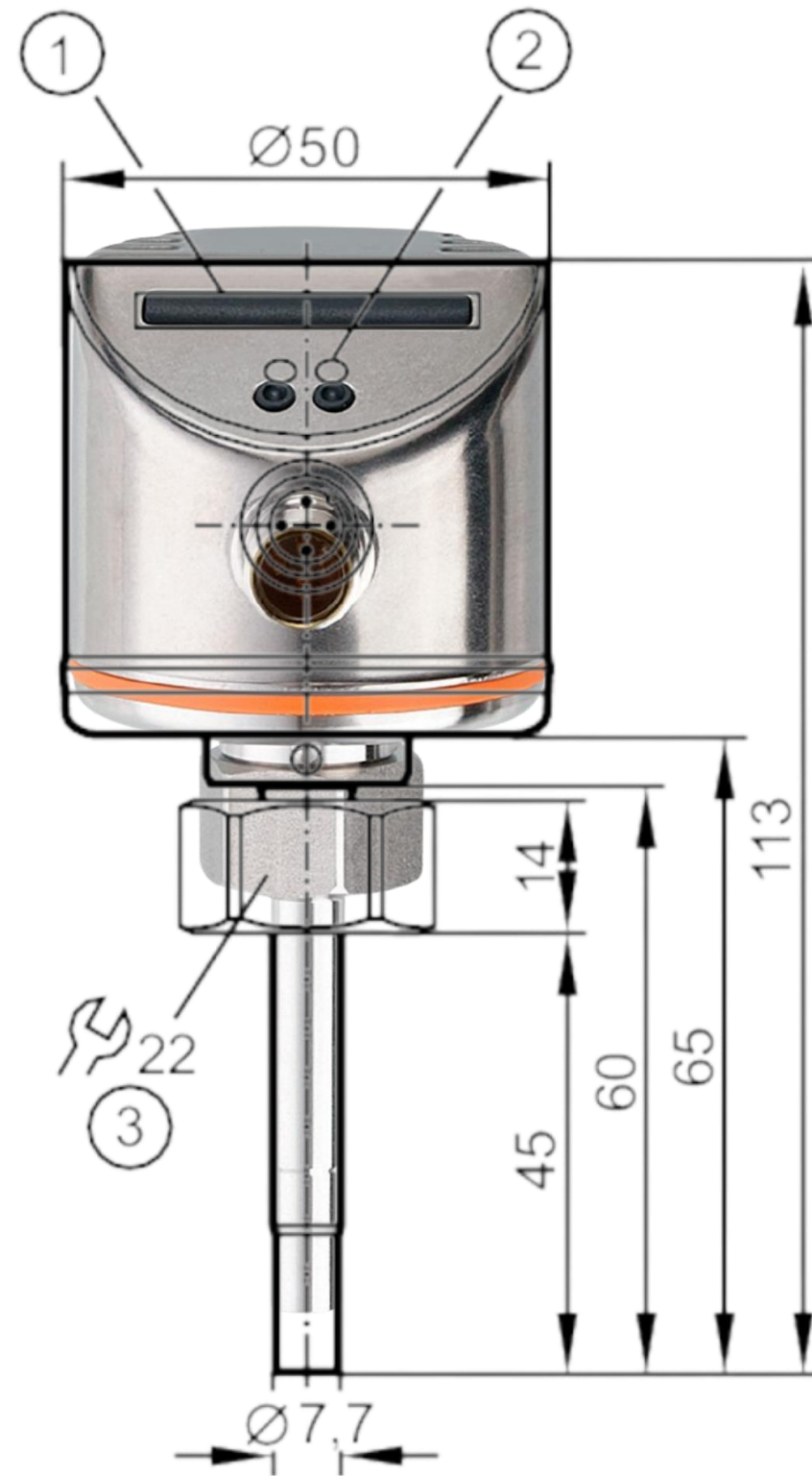

01 Problem – Technische Sprachbarriere

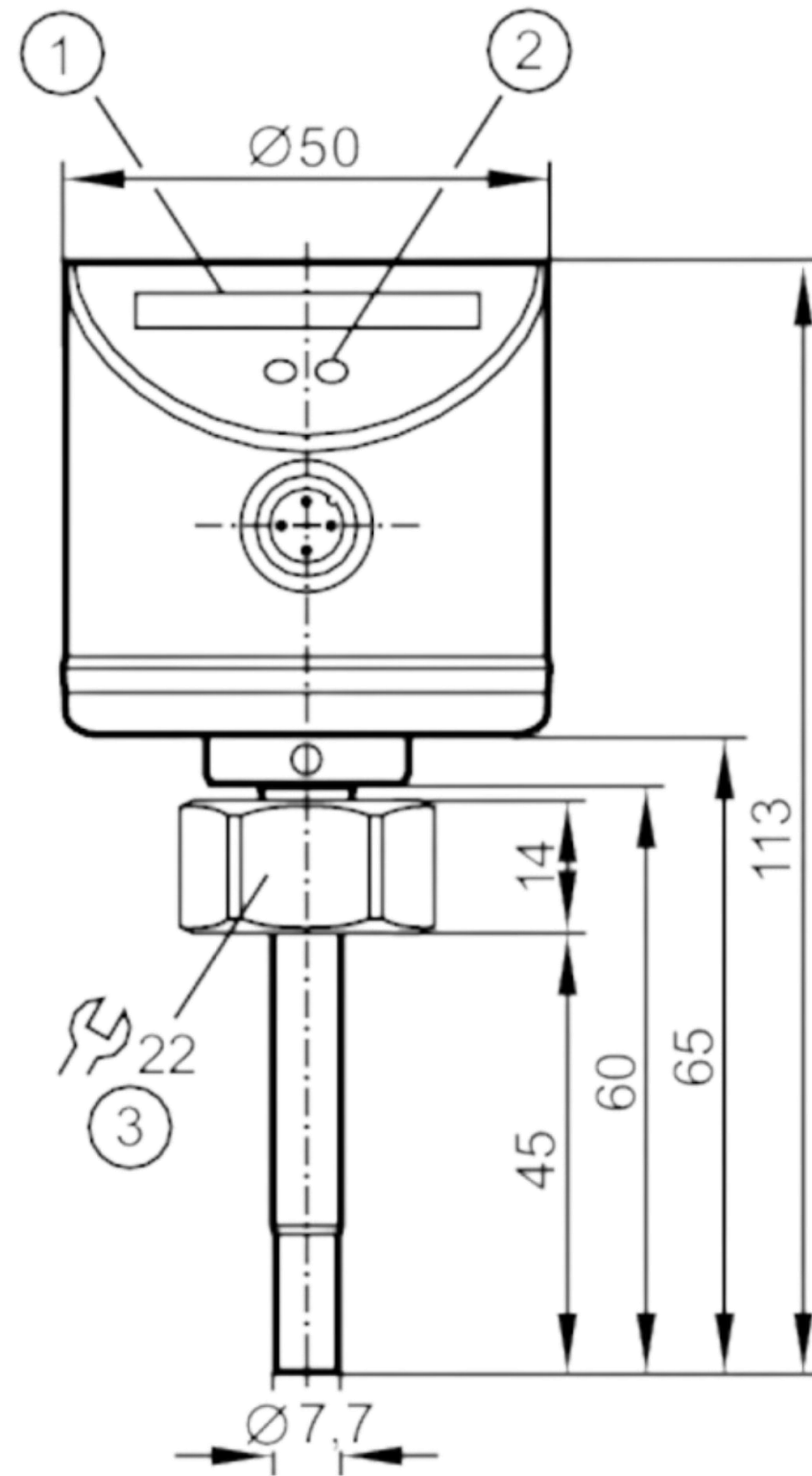

01 Problem – Technische Sprachbarriere

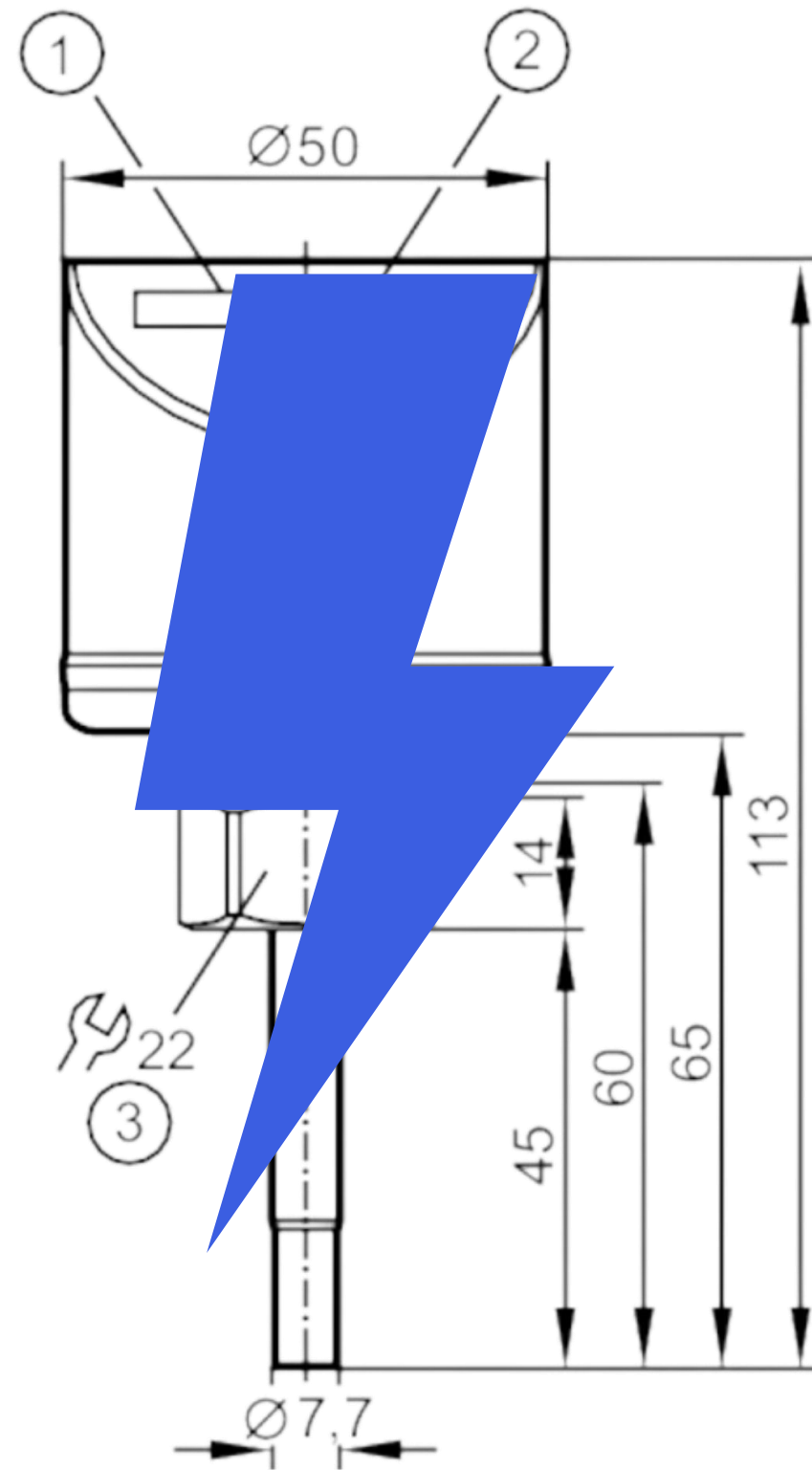

01 Problem - Digitaler B2B Vertrieb



Fehlende Informationen

83% B2B Einkäufer*innen wollen
mehr Informationen.

(Gartner)

01 Problem - Digitaler B2B Vertrieb



Hoher Zeitaufwand

B2B Einkauf benötigt 6,4 Stunden
pro Einkauf.

(International Data Group)

01 Problem - Digitaler B2B Vertrieb

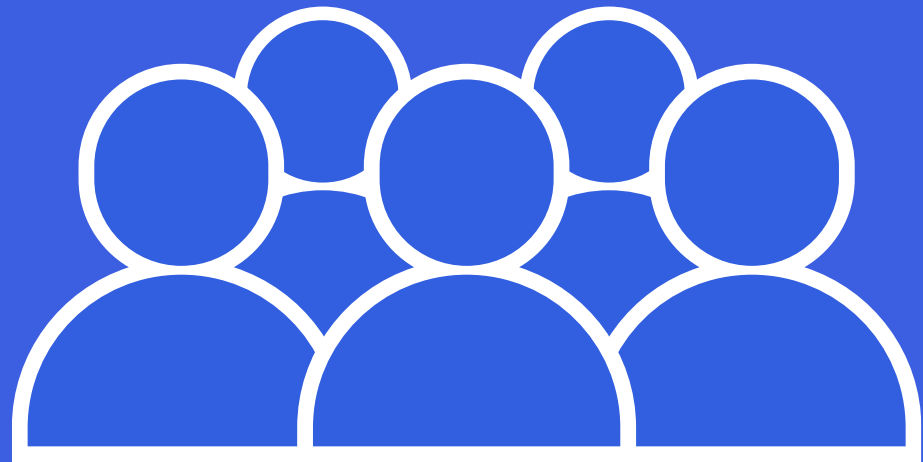

Komplizierter Prozess

Ein B2B Einkaufsprozess bindet 6,8
Personen

(HBR)

02 Lösung - Produktfinder

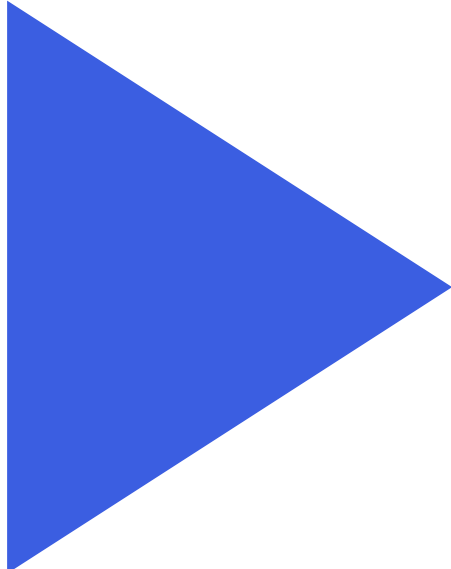

02 Lösung - Produktfinder

How?

03 Produkt - 3 Schritte zum Produktfinder

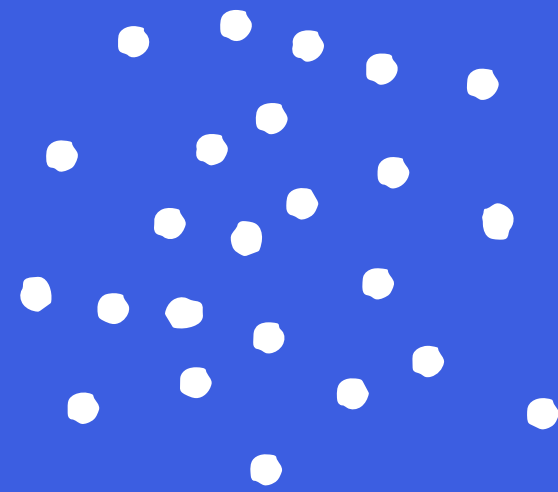

Language model

Fragen + Antworten +
Produktvorschläge¹



¹ ab Q3 2023

03 Produkt - 3 Schritte zum Produktfinder



03 Produkt - 3 Schritte zum Produktfinder

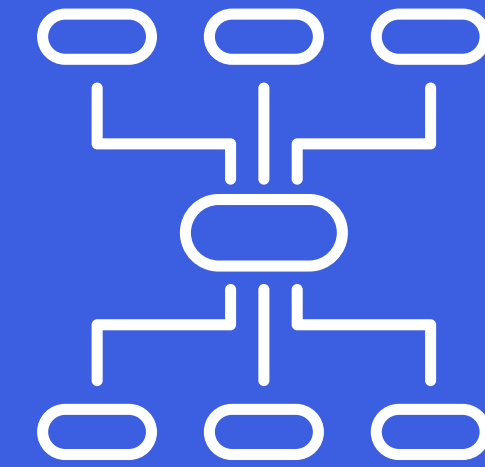

Next Best Question

Welche Frage kommt
als nächstes?

04 Angebot

1

Expert*in

1

Tag

1.000

Produkte

05 Beispiel

100.000
Verbindungselemente



BÖLLHOFF

06 Beispiel

300.000
Roboter Konfigurationen



Dominik Witt

dominik.witt@phaina.com

